

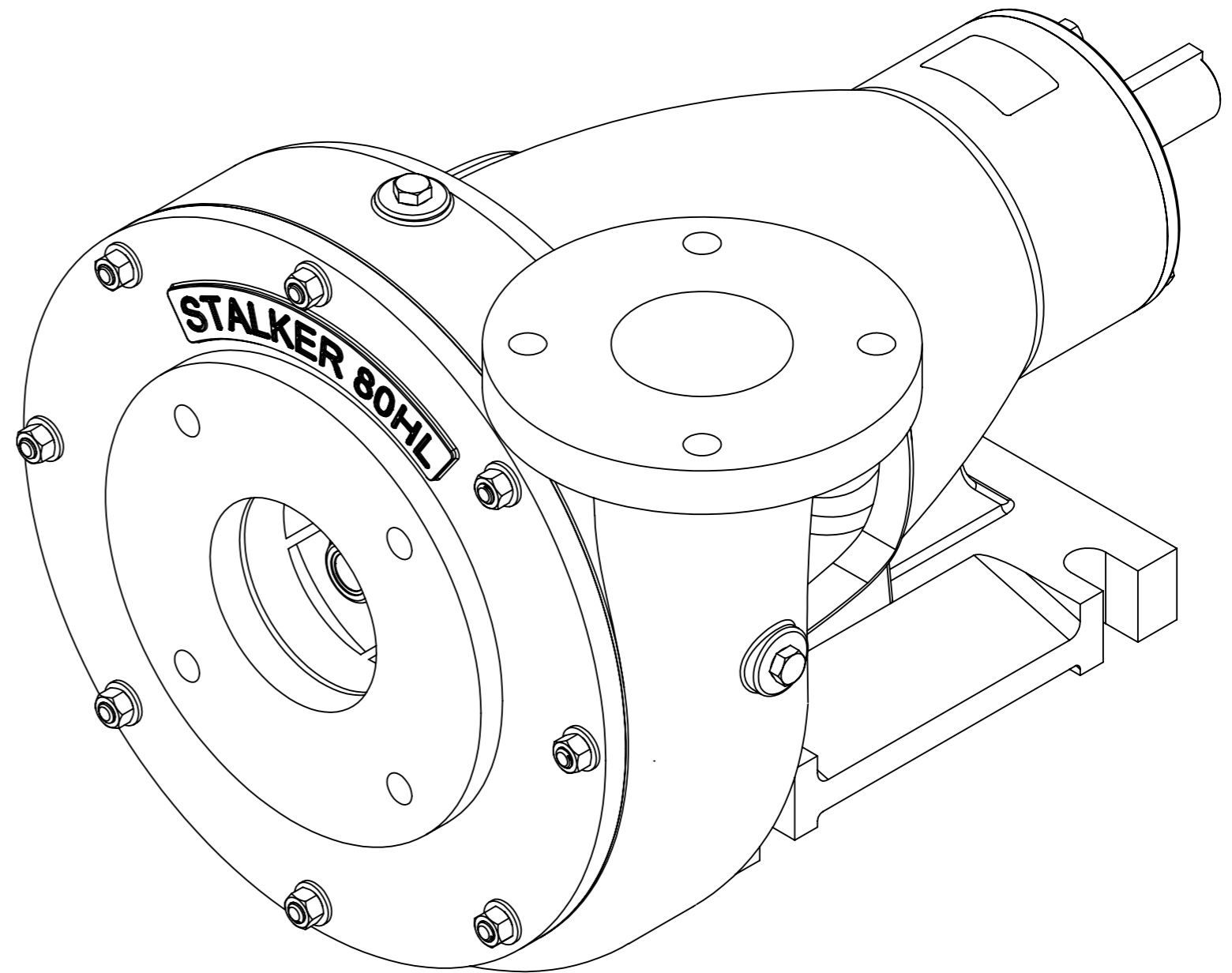

ITEM	PART NUMBER	DESCRIPTION	QTY.
01	0000010401	PEDESTAL - 80HL DC 508/509	1
02	0000020401	BEARING CAP (REAR)	1
03	0000030401	BEARING CAP (FRONT)	1
04	00004----1-	GLAND 1 1-4" SG IRON (1.25 x 38)	1
05	000005----1-	LATERN RING 1 1/4" ID x 2" OD	1
06.01	WASHER 10mm	WASHER 10mm	10
06.02	B082_38UNCZPN	NUT 3/8" UNC ZINC PLATED	8
06.03	B098_38ZPTGP	3/8" TAPER HEX GAS PLUG (ZINC PLATED)	2
06.04	B111_516X34UNCZPSS	SETSCREW - 5/16" DIAM x 3/4" UNC 8.8 ZINC PLATED	1
06.05	B111_516X34UNCG316B	5/16" DIAM x 3/4" UNC 316 SS	6
06.06	B011_12X1.12BSWZPB	BOLT 1/2" x 1-1/2" BSW (ZINC PLATED)	4
06.07	B119_38X1.14ENG	STUD - 3/8" x 1-1/4" ENG MS	8
06.08	B119_38X2G316ENG	STUD - 3/8" DAIM x 2" ENG 316 SS	2
07	51000704011	VOLUTE (CASING) - GLAND PACKED	1
09	51000904---2	GASKET COVER	1
10	B071_14X14X1G304KS	1/4" SQUARE KEY 304 SS (IMPELLER)	1
11	B082_34UNFG316NN	NYLOCK NUT 3/8" UNF SS (IMPELLER)	1
12	B051_5100120020	GASKET (VOLUTE)	1
13	51001304---2T	IMPELLER	1
14	000014----1-	NECK BUSH - TYPE 1 - 1 1/4" ID x 3/8" BRONZE	1
15	B090_00001503	PACKING - 1.25" ID 2" OD x 3/8" ROPE 130mm LONG	4
16	B08_38UNCG316NN	3/8" NYLOCK NUT - ZINC PLATED	2
19	00001904----T	TAPER SHAFT (NO ABUTMENT RINGS)	1
21	B132_RT29X70X3	THROWER RUBBER - 29 ID x 70 OD x 3 THK	1
50	B147_0000500406	IMPELLER WASHER - 508/509	1
51	B115_OS12089	OIL SEAL - TRG_000381 (38.1mm ID, 47.1mm OD)	2
52	B008_6309-2RS-C3	BEARING 6309 2RS-C3 BALL	2
54	B071_14X14X1G316NN	5/16" SQUARE KEY, KEY STEEL (SHAFT / DRIVE KEY)	1
84	B081_GN_18	1/8" BSP HYDRAULIC NIPPLE	1
84.01	B081_GN_18_90	GREASE NIPPLE - 1/8" BSP 90 DEGREE	1



REVISIONS			
REV.	DESCRIPTION	DATE	APPROVED
A	DRAWING CREATED	21/09/2012	STALKER

 STALKER PUMPS A DIVISION OF STALKER ENGINEERING www.stalkerpumps.com.au	<small>THIS DATA REMAINS THE PROPERTY OF STALKER ENGINEERING. NO DATA MAY BE REPRODUCED WITHOUT PRIOR CONSENT OF COMPANY. DATA MAY BE ALTERED WITHOUT NOTIFICATION.</small>	GENERAL TOLERANCES METRIC +/-0.400mm INCH +/-0.015" FABR +0/-2.0mm		DRAWN: E. HASSETT	TITLE: 80 HL 509 SERIES DC GLAND PACKED OVERALL VIEW & BOM
		"IF IN DOUBT ASK" 	SHEET NUMBER: Sheet1 OF 4	SCALE: 1:2.5	
"DO NOT SCALE"	MASS(kg): 95.15	APP FOR CONSTR: -	CHECKED: -	REVISION: A 18/09/2012	DRAWING No: 5100--04--12

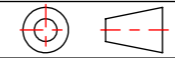
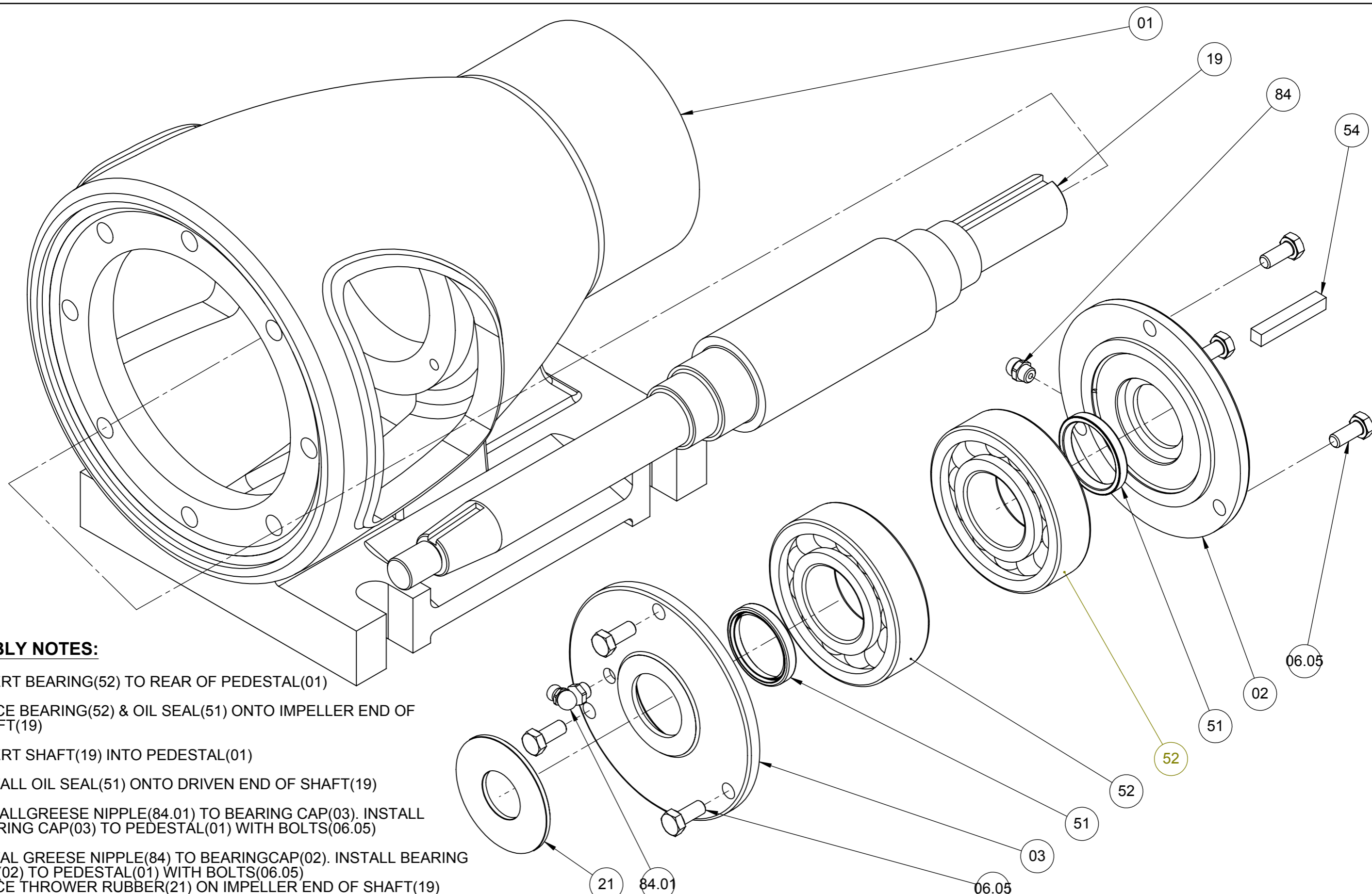

ASSEMBLY NOTES:

1. INSERT BEARING(52) TO REAR OF PEDESTAL(01)
2. PLACE BEARING(52) & OIL SEAL(51) ONTO IMPELLER END OF SHAFT(19)
3. INSERT SHAFT(19) INTO PEDESTAL(01)
4. INSTALL OIL SEAL(51) ONTO DRIVEN END OF SHAFT(19)
5. INSTALL GREASE NIPPLE(84.01) TO BEARING CAP(03). INSTALL BEARING CAP(03) TO PEDESTAL(01) WITH BOLTS(06.05)
6. INSTALL GREASE NIPPLE(84) TO BEARING CAP(02). INSTALL BEARING CAP(02) TO PEDESTAL(01) WITH BOLTS(06.05)
7. PLACE THROWER RUBBER(21) ON IMPELLER END OF SHAFT(19)

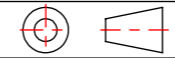
 STALKER PUMPS A DIVISION OF STALKER ENGINEERING www.stalkerpumps.com.au	<small>THIS DATA REMAINS THE PROPERTY OF STALKER ENGINEERING. NO DATA MAY BE REPRODUCED WITHOUT PRIOR CONSENT OF COMPANY. DATA MAY BE ALTERED WITHOUT NOTIFICATION.</small>		GENERAL TOLERANCES METRIC +/-0.400mm INCH +/-0.015" FABR +0/-2.0mm	DRAWN: E. HASSETT DATE: 04/09/2012	TITLE: 80 HL 509 SERIES DC GLAND PACKED PEDESTAL - SHAFT ASSEMBLY	
	"IF IN DOUBT ASK"			SHEET NUMBER: Sheet2 OF 4	SCALE: 1:2	DRAWING No: 5100--04--12
	"DO NOT SCALE"		MASS(kg): [APPROX.] 95.15	APP FOR CONSTR: - CHECKED: -	REVISION: A	A3 SIZE

ASSEMBLY NOTES:

1. INSERT STUDS(06.08) AT REAR OF CASING(07)
2. INSERT PACKING SET (14)(15)(05)(15)(15)(15) & GLAND(04) INTO CASING(14)
3. SECURE GLAND(04) WITH NUTS & WASHERS (16)(06.01) ****FINGER TIGHT****
4. SECURE CASING(14) TO PEDESTAL(01) WITH BOLTS(06.06)

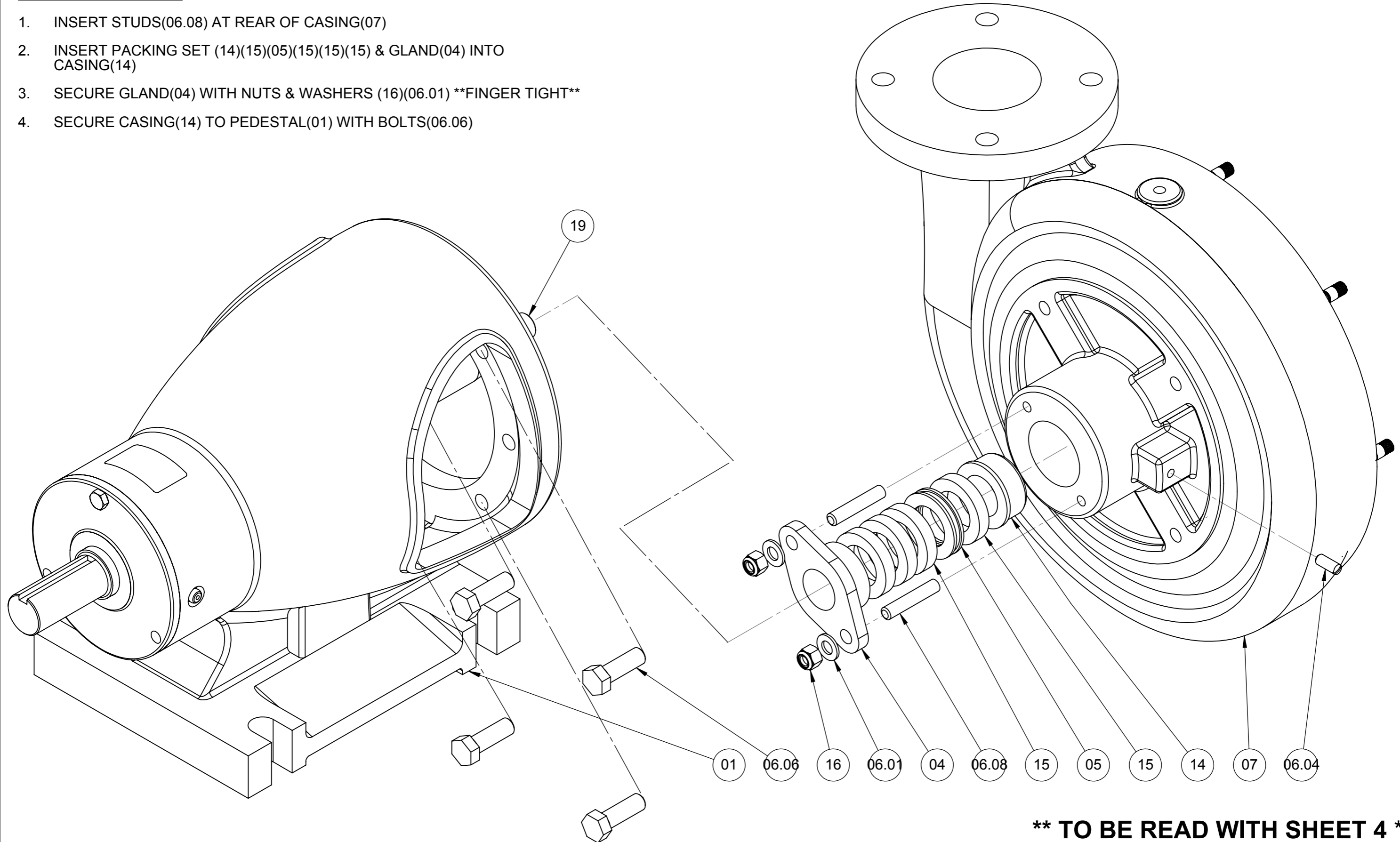

**** TO BE READ WITH SHEET 4 ****

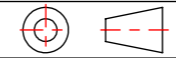
 <p>STALKER PUMPS A DIVISION OF STALKER ENGINEERING www.stalkerpumps.com.au</p>	<p>THIS DATA REMAINS THE PROPERTY OF STALKER ENGINEERING. NO DATA MAY BE REPRODUCED WITHOUT PRIOR CONSENT OF COMPANY. DATA MAY BE ALTERED WITHOUT NOTIFICATION.</p>	<p>GENERAL TOLERANCES</p> <p>METRIC +/-0.400mm INCH +/-0.015" FABR +/-2.0mm</p>		<p>DRAWN: E. HASSETT</p>	<p>TITLE: 80 HL 509 SERIES DC GLAND PACKED VOLUTE ASSMEBLY</p>
		<p>"IF IN DOUBT ASK"</p>		<p>SHEET NUMBER: Sheet3 OF 4</p>	
<p>"DO NOT SCALE"</p>	<p>MASS(kg): [APPROX] 95.15</p>	<p>APP FOR CONSTR: -</p>	<p>CHECKED: -</p>	<p>REVISION: A</p>	<p>DRAWING No: 5100--04--12</p>

ASSEMBLY NOTES:

1. INSERT STUDS(06.07) INTO FLANGE FACE OF CASING(07)
2. MOUNT IMPELLER(13) ONTO SHAFT(19) ALLIGN WITH KEY(10) & SECURE WITH NUT & WASHER (17)(19)
3. INSTALL GASKET(12) & MOUNT COVER(09), SECURE WITH NUTS & WASHERS (24)(30)
4. SPIN IMPELLER TO CHECK FREE OPERATION. IF SATISFACTORY, SECURE GLAND(04) NUTS(16)
5. INSTALL GAS PLUGS(06.03)

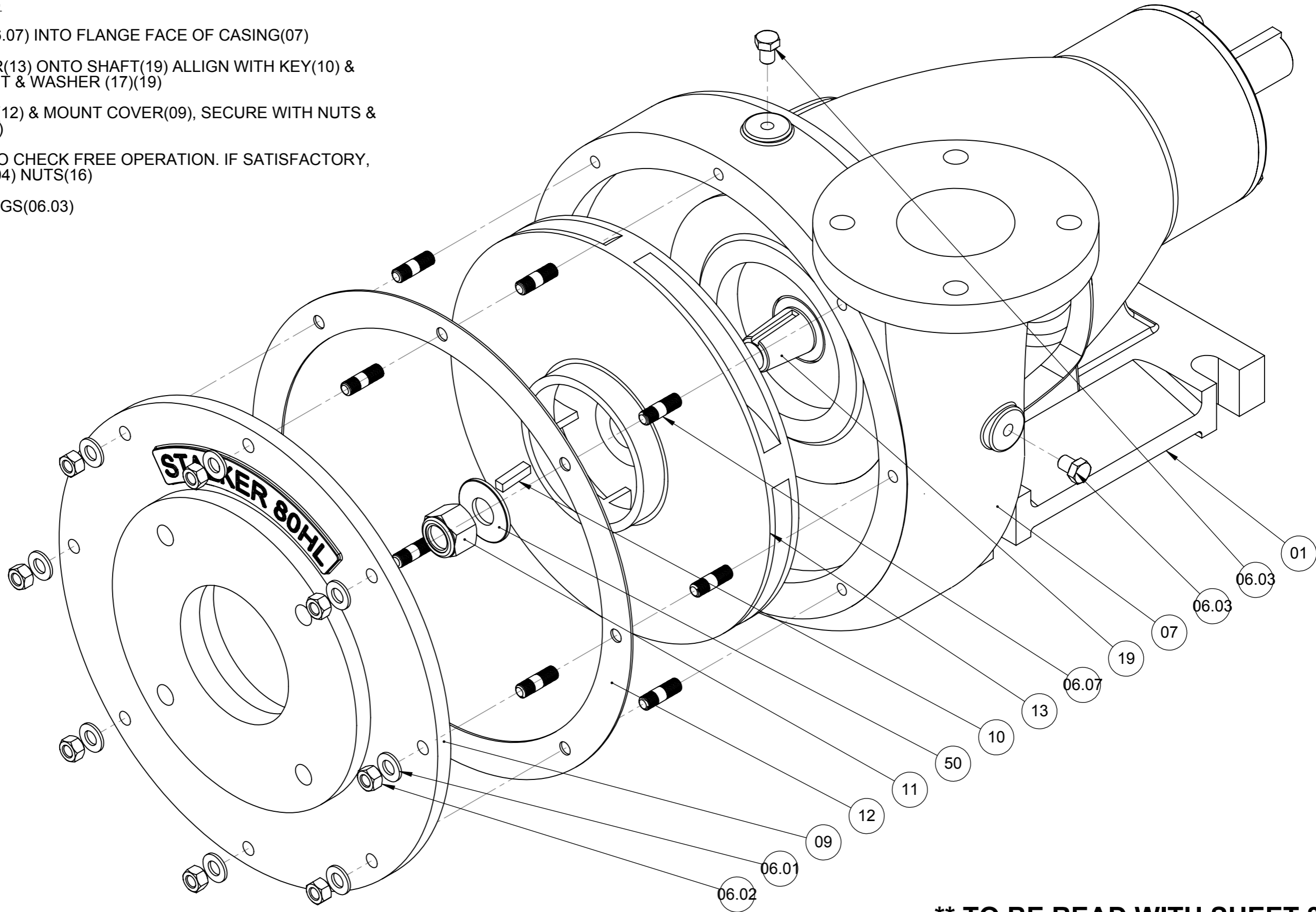

**** TO BE READ WITH SHEET 3 ****

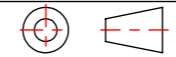
 STALKER PUMPS A DIVISION OF STALKER ENGINEERING www.stalkerpumps.com.au	<small>THIS DATA REMAINS THE PROPERTY OF STALKER ENGINEERING. NO DATA MAY BE REPRODUCED WITHOUT PRIOR CONSENT OF COMPANY. DATA MAY BE ALTERED WITHOUT NOTIFICATION.</small>		GENERAL TOLERANCES METRIC +/-0.400mm INCH +/-0.015" FABR +0/-2.0mm		DRAWN: E. HASSETT	TITLE: 80 HL 509 SERIES DC GLAND PACKED IMPELLER INSTALLATION DRAWING No: 5100--04--12	A3 SIZE		
	"IF IN DOUBT ASK"				SHEET NUMBER: Sheet4 OF 4			DATE: 04/09/2012	SCALE: 1:2.5
	"DO NOT SCALE"		MASS(kg): [APPROX] 95.15		APP FOR CONSTR: -			CHECKED: -	REVISION: A